

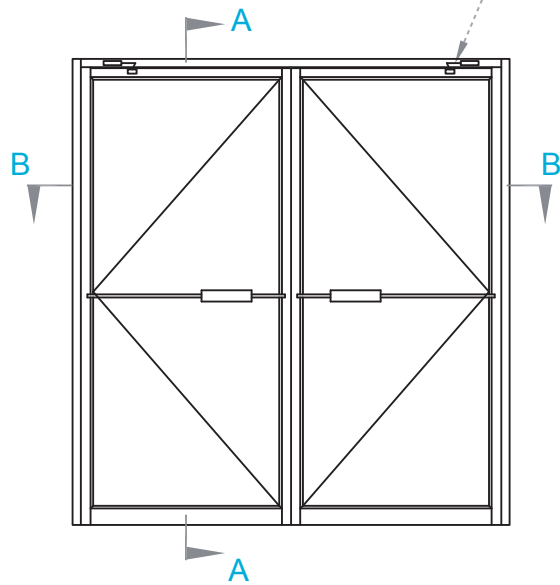

Puerta Batiente

ENSAMBLE

DISEÑO TIPO



CIERRAPUERTAS
SUPERIOR
DE BRAZO

SECCIÓN VERTICAL (A - A)

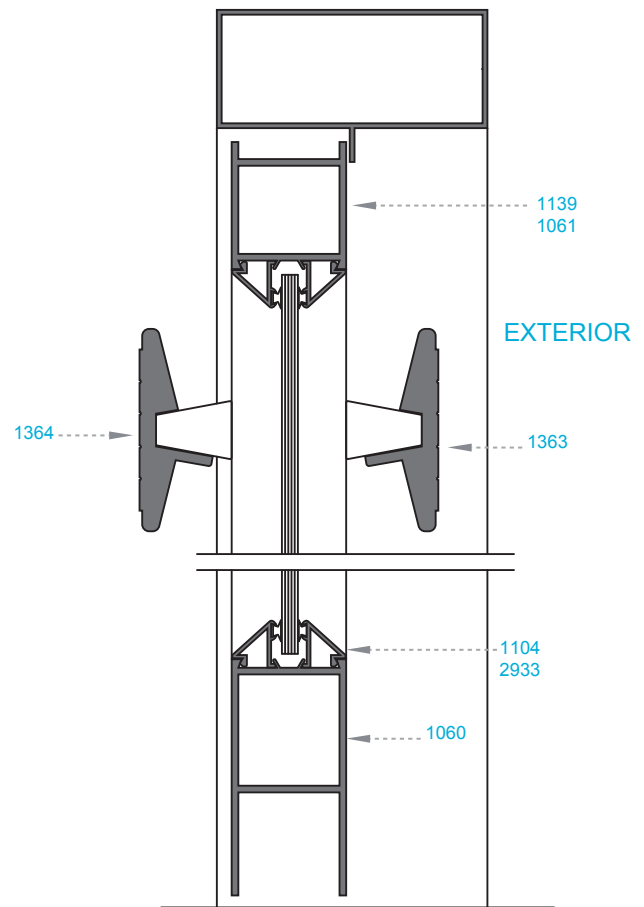

SECCIÓN HORIZONTAL (B - B)

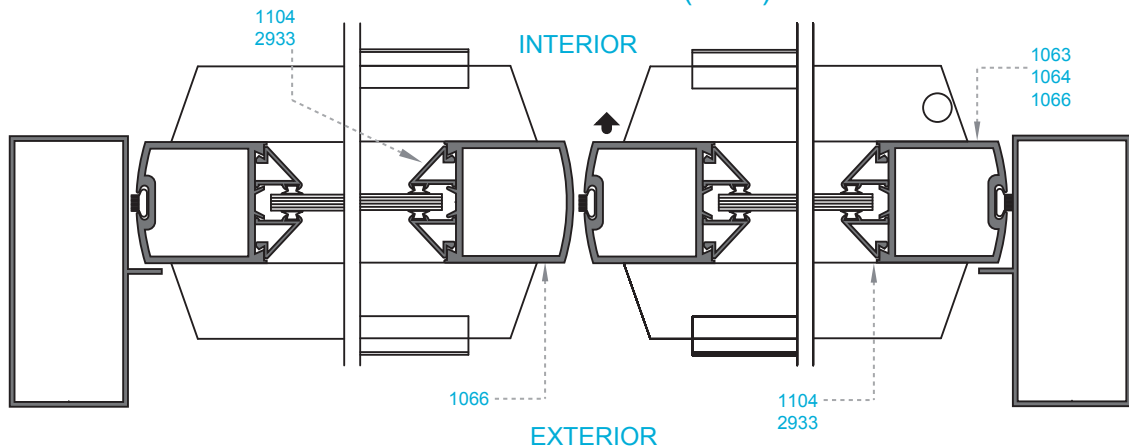



Puerta Batiente

Escala: 1:1
Medida: Milímetros

REFERENCIAS

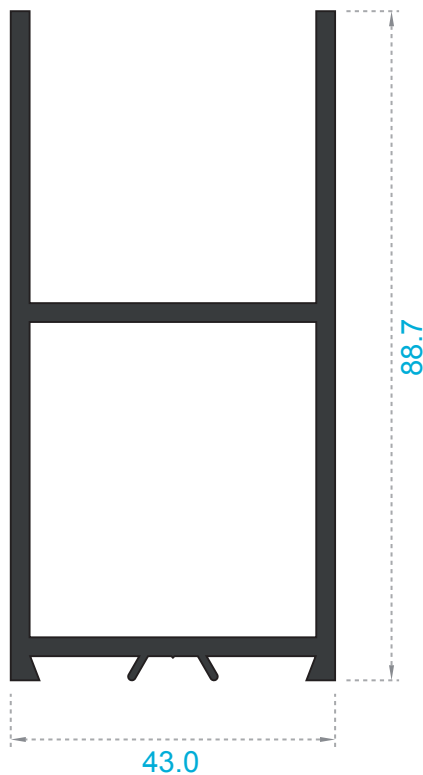

Nombre	Referencia	Peso
Horizontal Inferior de Hoja	1060	1.748Kg/m.

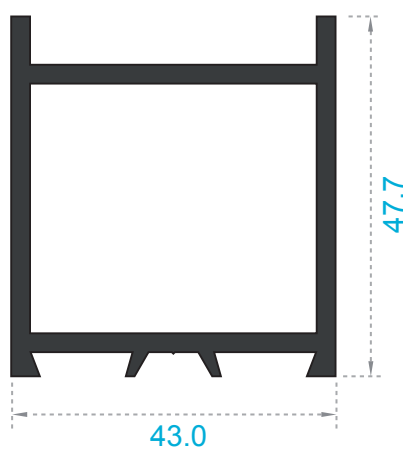

Nombre	Referencia	Peso
Horizontal Superior de Hoja	1061	1.201Kg/m.



Puerta Batiente

Escala: 1:1
Medida: Milímetros

REFERENCIAS

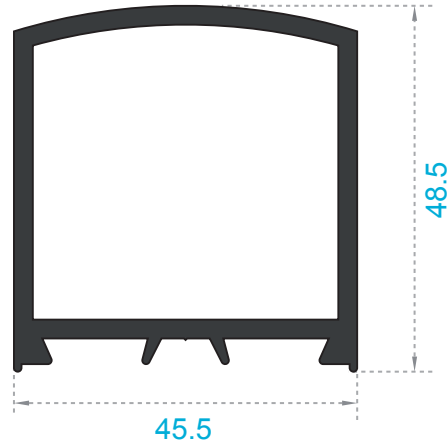

Nombre	Referencia	Peso
Vertical	1066	1.221Kg/m.

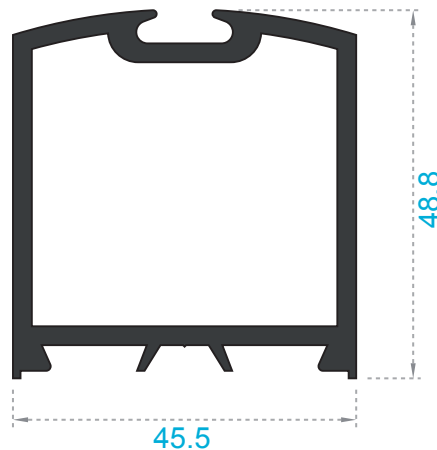

Nombre	Referencia	Peso
Vertical para Felpa	1063	1.314Kg/m.



Puerta Batiente

Escala: 1:1
Medida: Milímetros

REFERENCIAS

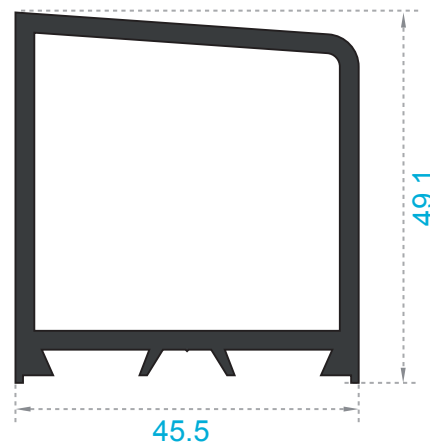

Nombre	Referencia	Peso
Vertical Giro 90°	1064	1.236Kg/m.

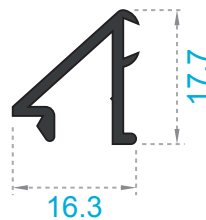

Nombre	Referencia	Peso
Pisa Vidrio	1104	0.176Kg/m.



Puerta Batiente

Escala: 1:1
Medida: Milímetros

REFERENCIAS

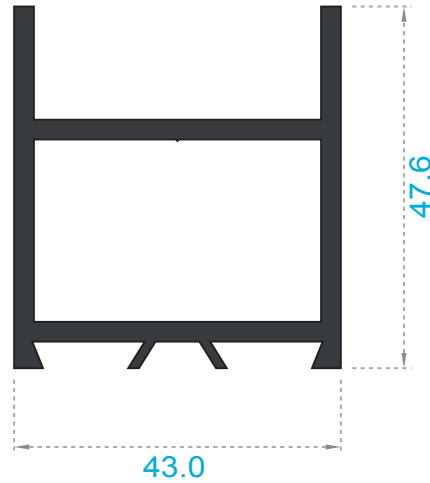

Nombre	Referencia	Peso
Horizontal Superior de Hoja	1139	1.240Kg/m.



Nombre	Referencia	Peso
Porta Felpa	1370	0.259Kg/m.

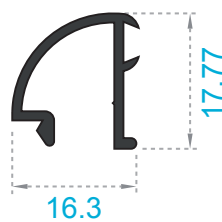

Nombre	Referencia	Peso
Pisa Vidrio	2933	0.169Kg/m.